



## Product Portfolio

# Optical Glass

Sumita develops and manufactures more than 200 types of optical glass products including preforms for precision molding and advanced glass materials.



# Optical System

We offer customized optical solutions including molded aspheres, specialty lenses, and optical devices. Our engineering department is available to assist with product designs and development.

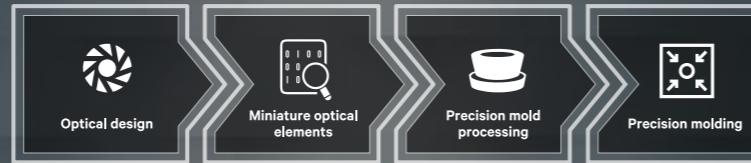

# Optical Fiber

We draw optical fiber and manufacture light guides for a wide range of fields including image processing, sensing, medical equipment and lighting.



# Medical Imaging

Sumita's core technologies integrated to Medical Imaging. We provide ultra-thin endoscope parts.

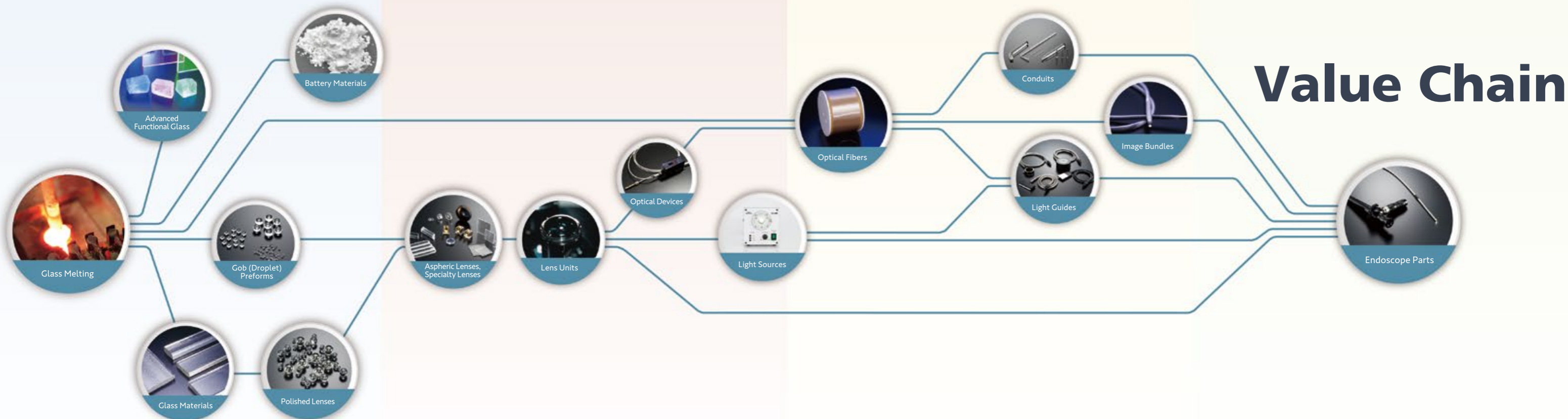
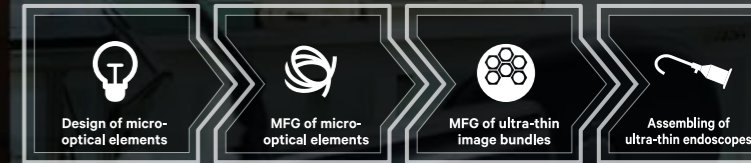

# Delivery Forms

## Polished Balls

Polished balls with precise roundness, achieved through grinding and polishing treatments, are primarily utilized in optical communication and sensor fields, such as fiber optic focusing, docking, and collimation.



Specifications	
Shapes	Sphere
Diameter (mm)	$\phi$ 1.2 – $\phi$ 20
Sphericity (mm)	$\leq \phi \pm 0.005$
Surface finish	Mirror polishing

\* If you require more than the information provided above, please feel free to contact us.  
 \* K-PSFn1 and K-PSFn3 may experience solar degradation when exposed to prolonged sunlight conditions. Feel free to contact us in advance.  
 \* Customized products with a wide range of specifications are available.

## Rods

As a material for lens processing, it is commonly used for small to large-scale production, achieving high-precision and low-cost external machining.

**Characteristics:** It can accommodate small to large-scale production, and it is possible to make the side surfaces mirror-finished.

**Applications:** Blanks for small diameter lenses



Specifications	
Diameter (mm)	$\phi$ 2 – $\phi$ 25
External diameter tolerance (mm)	$\pm 0.1$ ( $\pm 0.015$ if below Rz1)
Max. length (mm)	150
Min. lot size	100 pcs. /batch

\*The maximum length may vary and could be shorter depending on the specific glass types employed.

## Pressed Blanks

As a material for lens processing, it is the most common processing material. It can be used for small to large-scale production, allowing for high-precision, low-cost machining of various shapes.

**Characteristics:** Suitable for small-scale production of multiple varieties, excellent processability, high precision, and low cost.

**Applications:** Blanks for various lenses and prisms



Specifications	
Diameter (mm)	$\phi$ 6 – $\phi$ 220
Shapes	Biconvex, plano-convex, concave-convex (meniscus)
Min. lot size	100 pcs. /batch

\*For inquiries regarding special shapes, please feel free to contact us.

## Droplet Preforms

A "droplet ball preform" is a spherical preform lens molded directly from molten glass. It offers the advantages of a short delivery time, low cost, and quick response for reproduction.

\*In order to prevent defects, please wrap the preforms in a dust-free clean bag when storing for future use.

### Approximate Spherical Droplet Preforms

1 – 3 mm or less in diameter are available.

### Corresponding glass types

K-VC89/80/79/78, K-PSK100/200/300, K-PSFn3, K-CSK120, K-SKLD120/200, K-PG375

Specifications			
Diameter (mm)	Diameter tolerance (mm)	Sphericity (mm)	Volume (mm <sup>3</sup> )
$\phi$ 1.0 – $\phi$ 1.5	$\pm 0.020$	$< 0.030$	0.524 - 1.767
$\phi$ 1.5 – $\phi$ 2.0	$\pm 0.020$	$< 0.040$	1.767 - 4.189
$\phi$ 2.0 – $\phi$ 2.3	$\pm 0.030$	$< 0.050$	4.19 - 6.37
$\phi$ 2.3 – $\phi$ 2.5	$\pm 0.030$	$< 0.060$	6.37 - 8.18
$\phi$ 2.5 – $\phi$ 3.0	$\pm 0.040$	$< 0.080$	8.18 - 14.14

## Standard Droplet Preforms

An oval shape is available for 3 mm or more in diameter.

\*The aforementioned diameter is frequently used. Should you require a different diameter, please reach out to us.

Specifications and Parameters			
Glass types	Volume (mg)	Glass types	Volume (mg)
K-VC78	50 - 1,700	K-PBK50	100 - 750
K-VC79	50 - 3,000	K-PSFn3	60 - 500
K-VC80	60 - 3,000	K-PG375	50 - 220
K-VC89	70 - 3,000	K-CD45	50 - 750
K-PSK100	50 - 1,000	K-SKLD120	50 - 3,000
K-PSK200	50 - 400	K-SKLD200	50 - 3,000
K-PSK300	70 - 600	K-PBK60	500 - 3,000
K-CSK120	50 - 5,000		

\*If alternative types are required, please reach out to us.

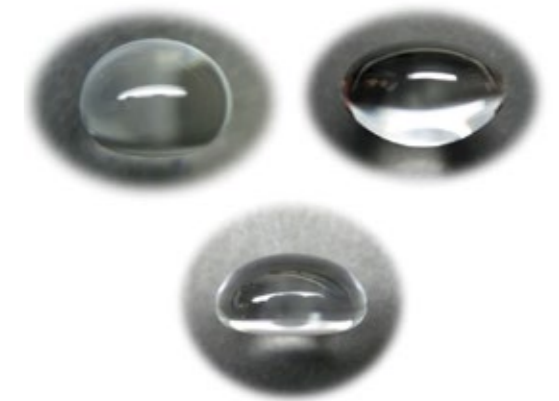

## Shaped Droplet Preforms

Molten glass is directly dropped and shaped, providing a diverse selection of shapes for customers in search of specialized preforms that cannot be achieved through polishing.

- Can be used as preforms or for other applications
- Suitable for mass production
- Incorporating natural tension after dropping, the chamfering features a smooth, rounded finish, eliminating the need for additional chamfering





## YAGGLASS-T NIR to Visible Wavelength Converting Glass

- Converts invisible near-infrared light, such as YAG laser beam, to visible light with high efficiency
- With high transparency
- RoHS compliant
- Custom dimensions are available upon request

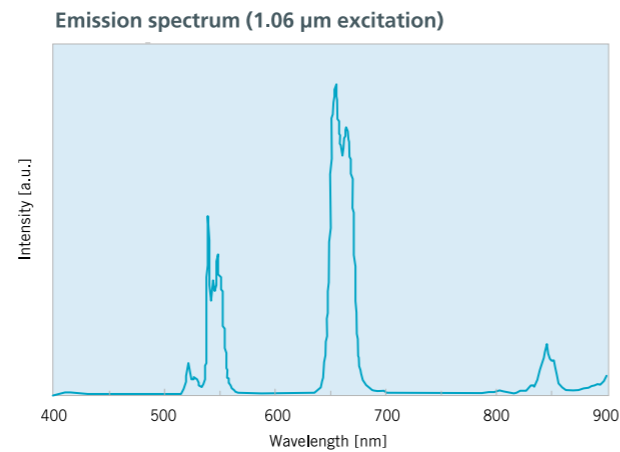
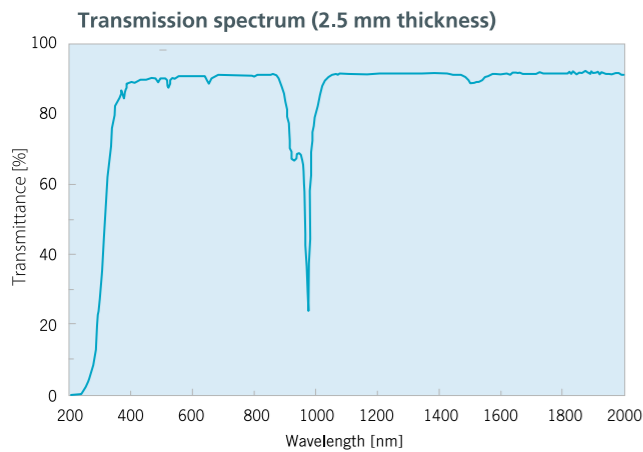
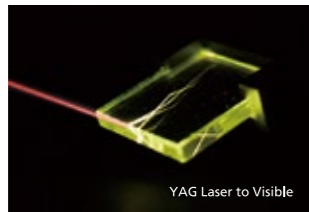

Specifications and Basic Properties	
Dimensions of detection glass (off-the-shelf product)	20 x 20 x 2.5 mm
Detectable wavelength range	0.9 - 1.07 μm
Detecting sensitivity (irradiated laser: 1.06 μm)	30 mW/mm <sup>2</sup>
Emission wavelength	0.55 μm, 0.66 μm
Surface damage threshold (irradiated laser: wavelength of 1.06 μm, pulse width of 10 ns)	51 J/cm <sup>2</sup>
Refractive index (nd)	1.539
Transformation point (Tg)	584°C
Thermal expansion coefficient (100 – 300°C)	89 x 10 <sup>-7</sup> /°C
Specific gravity (S.g)	3.4

\*Never look at laser beam directly or through lens. Diffused reflected beam is also harmful.  
 \*Wear laser protective goggles for operator's eyes. The goggles should be used against scattered beam. Be sure to wear goggles to protect your eyes.  
 \*The detection part is made of glass. Please handle with care.

## Lumilass UV to Visible Light Converter Fluorescent Glasses

- Converts a faint UV source of 200 – 400 nm light into visible light with high efficiency
- High sensitivity that allows for visible light detection since a large amount of luminous ions are contained
- Minimum sensitivity of - 1 μW/cm<sup>2</sup> for all emissions
- High transparency, homogeneity
- Superior durability and water resistance
- Keeps high performance after long-hours irradiation with UV light
- Excellent machinability, so it can be processed in various forms
- RoHS compliant

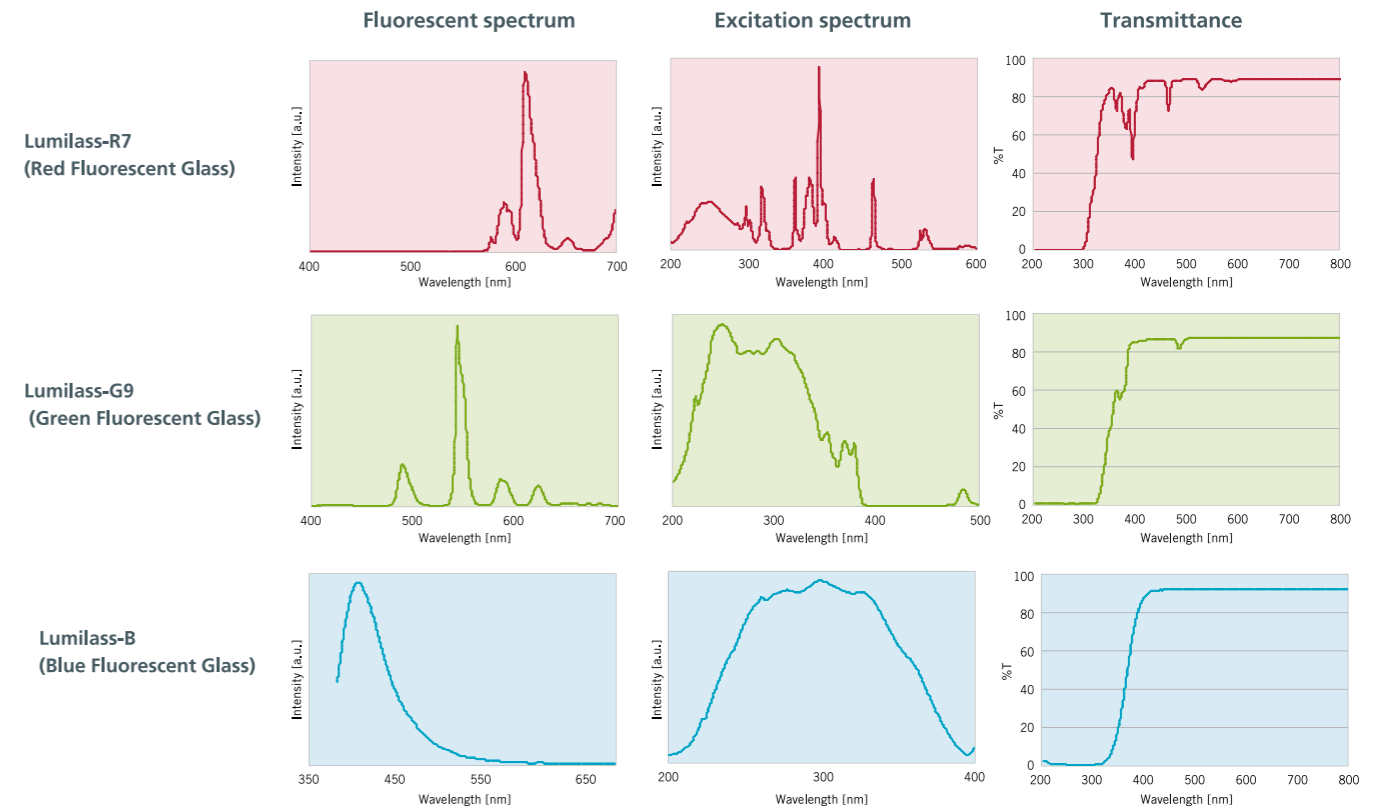

	Optical Properties		
	Lumilass-R7	Lumilass-G9	Lumilass-B
Peak emission wavelength (nm)	610	540	405
Excitation wavelength range (nm)	200 - 420	200 - 390	200 - 400
Min. excitation sensitivity (- 1 μW/cm <sup>2</sup> )	~ 1	~ 1	~ 1
Refractive index (nd)	1.644	1.694	1.477

	Thermal and Mechanical Properties		
	Lumilass-R7	Lumilass-G9	Lumilass-B
Transformation point Tg (°C)	594	660	398
Thermal expansion coefficient (α × 10 <sup>-7</sup> )	86	73	176
Specific gravity (S.g)	3.77	3.76	3.65
Vickers hardness (Hv)	633	765	344
Young's modulus E (× 108N/m <sup>2</sup> )	900	1140	650
Modulus of rigidity G (× 108N/m <sup>2</sup> )	340	440	250

# Optical Glass for New Lens Designs

## Optical Glass for Precision Molding

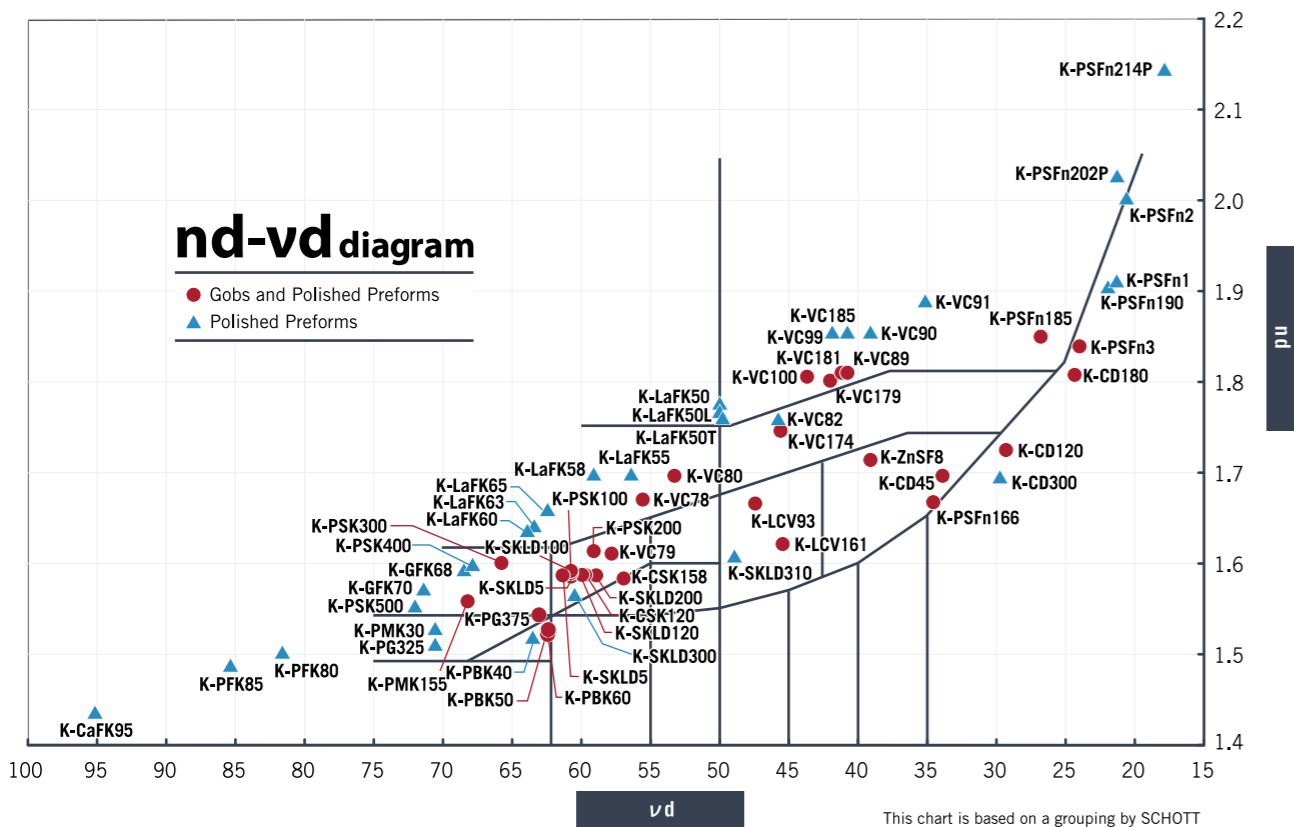

## Optical Index Values & Other Properties

Tg: Transformation point / At: Yielding point / α: Thermal expansion (100~300°C) / DW: Chemical durability

Rec. *10	Glass type	Catalogue value		After molding*1		Tg(°C)	At(°C)	α x 10 <sup>-7</sup>	DW	S.g	Available form*2	Coloration*3
		nd	νd	nd	νd							
	K-PSFn214P	2.14400	17.8	2.13919	17.8	427	452	99	1	7.07	△	(52)/42*4
	K-PSFn202P	2.02160	21.4	*7	*7	457	487	86	1	6.25	△	(47)/40
	K-PSFn2	2.00170	20.6	1.99670	20.6	480	514	92	1	5.48	△	(50)/40*4
	K-PSFn1	1.90680	21.2	1.89948	21.4	498	543	102	1	4.15	△	(49)/39*4
	K-PSFn190	1.90460	21.5	1.89816	21.6	497	551	93	1	4.15	△	(43)/39*4
	K-VC91	1.88660	35.0	1.88176	34.9	589	638	95	1	4.87	△	(41)/36*4
	K-VC185	1.85375	40.6	1.84909	40.4	617	655	70	1	5.00	△	(37)/32*4
	K-VC90	1.85280	39.0	1.84859	38.9	583	633	94	1	4.98	△	(38)/34*4
	K-PSFn185	1.85070	26.9	1.84524	27.1	537	585	101	1	4.17	●	(40)/36*4
	K-VC99	1.85060	41.6	1.84604	41.5	616	653	73	1	5.15	△	(38)/32*4
☆	K-PSFn3	1.83917	23.9	1.83352	24.0	477	515	118	1	3.90	○	(43)/38*4
	K-VC181	1.81055	41.1	1.80614	41.0	548	584	79	1	4.71	○	40/34
★★	K-VC89	1.81000	41.0	1.80589	40.9	528	559	83	1	4.75	○	40/34
	K-CD180	1.80645	24.4	1.79912	24.7	553	588	113	1	3.17	●	44/37
	K-VC100	1.80400	43.6	1.79916	43.5	570	609	72	1	4.71	●	40/34
	K-VC179	1.79890	41.8	1.79441	41.8	523	561	80	1	4.65	●	39/34
★	K-LaFK50	1.77200	50.0	1.76831	49.6	560	592	90	1	5.20	△	37/29
	K-LaFK50L	1.76820	50.0	1.76454	49.7	528	566	93	1	5.15	△	37/28
	K-LaFK50T	1.76600	49.8	1.76209	49.6	576	612	81	1	4.75	△	37/30
★★	K-VC82	1.75550	45.6	1.75029	45.4	526	563	80	1	4.25	△	38/33
	K-VC174	1.74850	45.3	1.74578	45.1	524	562	105	1	3.92	●	38/31
☆☆	K-CD120	1.72250	29.2	1.71468	29.6	508	549	119	1	3.01	○	43/36
	K-ZnSF8	1.71430	38.9	1.71142	38.9	518	546	60	2	3.72	●	39/34
	K-LaFK58	1.69560	59.0	1.69097	58.6	542	577	93	1	4.56	△	36/28
★★	K-LaFK55	1.69400	56.3	1.68874	55.7	514	556	91	1	4.34	△	37/29
★★	K-VC80	1.69384	53.1	1.68984	52.8	530	566	94	1	3.81	○	36/29
☆☆	K-CD45	1.69320	33.7	1.68673	34.1	470	507	121	1	3.13	○	41/35
	K-CD300	1.69220	29.6	1.68558	29.9	482	519	141	1	2.78	△	41/36
★★★	K-VC78	1.66955	55.4	1.66625	55.2	520	556	100	1	3.44	○	35/28
	K-LCV93	1.66520	47.3	1.66355	47.2	547	578	46	1	3.64	○	38/33
	K-PSFn166	1.66300	34.4	1.65858	34.3	488	538	113	1	3.11	●	39/34
	K-LaFK65	1.65670	62.3	1.65224	62.0	506	542	103	1	4.36	△	36/28
	K-LaFK63	1.63860	63.4	1.63463	63.0	486	524	118	1	4.36	△	35/25
	K-LaFK60	1.63246	63.8	1.62847	63.2	485	528	114	1	4.27	△	38/28
	K-LCV161	1.61820	45.3	1.61477	45.6	426	469	67	2	3.26	●	36/32
	K-PSK200	1.61305	59.0	1.61083	58.9	386	412	123	1	3.38	○	34/31
★★★	K-VC79	1.61035	57.9	1.60736	57.5	516	553	93	2	3.09	○	34/29
	K-SKLD310	1.60420	48.9	1.60132	49.0	519	568	71	1	2.72	△	37/34
	K-PSK300	1.59950	65.6	1.59690	65.3	463	498	128	2	3.49	○	36/31
	K-PSK400	1.59500	67.8	1.59179	67.6	568	597	129	1	4.05	△	37/32
	K-GFK68	1.59240	68.3	1.58999	68.1	512	536	152	1	4.51	△	34/28
	K-PSK100	1.59170	60.7	1.58793	60.5	390	415	114	1	3.24	○	36/32
	K-SKLD100	1.59110	60.7	1.58773	60.4	520	560	85	3	2.69	○	36/30
★★★	K-SKLD5	1.58913	61.2	1.58606	61.0	521	560	82	3	2.67	○	36/30
	K-CSK120	1.58700	59.6	1.58444	59.2	498	536	91	2	3.00	○	35/31
	K-SKLD120	1.58680	59.8	1.58401	59.5	512	548	85	1	2.64	○	35/30
	K-SKLD200	1.58660	59.0	1.58355	58.8	507	548	88	1	2.70	○	35/30
	K-CSK158	1.58400	56.9	1.58157	56.7	473	529	112	2	3.06	●	34/31
	K-GFK70	1.56907	71.3	1.56626	71.2	485	509	156	1	4.48	△	34/28
	K-SKLD300	1.56420	60.4	1.56124	60.1	509	551	72	1	2.60	△	35/30
	K-PMK155	1.55820	68.2	1.55471	68.0	460	492	126	5	2.74	●	35/28
☆	K-PSK500	1.55215	71.9	1.55000	71.7	495	526	129	1	3.76	△	34/27
	K-PG375	1.54250	62.9	1.53921	62.5	344	367	160 <sup>5</sup>	2	2.90	○	36/31
★	K-PBK60	1.52740	62.3	1.52483	61.9	495	549	74	1	2.45	○	34/29
★★	K-PMK30	1.52500	70.4	1.52003	69.9	528	572	87	2	2.60	△	33/29
★★★	K-PBK50	1.52250	62.3	1.52023	62.0	481	518	92	2	2.43	○	34/29
	K-PBK40	1.51760	63.5	1.51497	63.4	501	549	73	2	2.39	△	33/29
	K-PG325	1.50670	70.5	1.50506	70.3	288	317	165 <sup>6</sup>	1	3.00	△	34/30
☆	K-PFK80	1.49700	81.5	1.49533	80.9	461	483	154	1	3.60	△	34/27
☆	K-PFK85	1.48563	85.2	1.48375	85.0	452	484	163	1	3.97	△	34/29
	K-CaFK95	1.43425	95.0	1.43312	95.0	431	450	167	1	3.54	△	33/28

\*1 ... Reference value after molding by SUMITA

\*2 ... ○: Gobs and polished preforms. Please contact us for possible dimensions.

●: Polished preforms. Please contact us regarding availability of gobs.

△: Polished preforms.

\*3 ... Wavelength for transmittance 0.8 and 0.05 in units of 10 nm

\*4 ... Wavelength for transmittance 0.7 and 0.05 in units of 10 nm

\*5 ... Temperature range: 50 - 250°C

\*6 ... Temperature range: 50 - 200°C

\*7 ... Measurement in progress

\*8 ... Additional information is available upon request.

\*9 ... Some glasses can be out of stock. Contact us to check stock availability in advance.

\*10 ... White stars have a limit on the diameter

# Molded Special Form Optics

## Precision Molded Aspheres

Diameter: 0.35 to 54mm

- Aspherical lenses made by precision molding are applied in digital cameras, pickup lenses, optical communications, sensing and other fields
- Typical volumes are available from smaller volumes for trial production including optical design to series production (up to 100K per year)

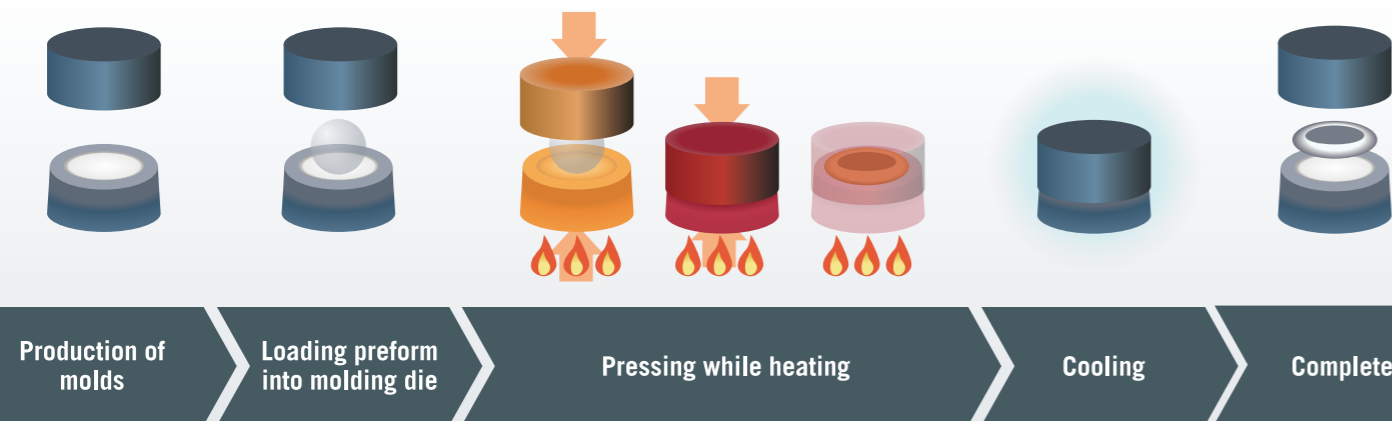

Specifications Customized upon your request	
Lens diameter	Φ0.35 mm – Φ54 mm
Center thickness	0.2 mm - 20 mm
Lens shape	Biconvex, convex-concave, biconcave
Radius of curvature	0.4 mm - upon request
Coating	AR and other types of coatings

\*Customized lenses within the above specifications range are available upon request.

Accuracy of Precision Molded Lenses		
	General accuracy value	Best measurement value
Lens diameter	± 0.02 mm	± 0.005 mm
Center thickness	± 0.03 mm	± 0.005 mm
Deviation and irregularity	3 (1)	1 (0.5)
Surface accuracy	P-V ≤ 1 μm	P-V ≤ 0.5 μm
Centration (transmission eccentricity)	1'	0.2'
Surface roughness	Ra 0.005 μm	Ra 0.003 μm
Lens thickness	0.6 mm	0.76 mm
Lens sag	25 μm	10 μm

\*Customized lenses within the above specifications range are available upon request.

## Aspherical Microlens Arrays

Our precision-molded microlens arrays use glass materials with excellent environmental resistance and temperature characteristics, making them compliant with Telcordia Standards. We offer samples of microlens arrays both for collimators and LD coupling. Leveraging our mold production capabilities and standard dies, we achieve cost-effective production and high volumes of over 10,000 units per month.

**Applications:** Collimator Lens for telecommunication / Coupling Lens for telecommunication / Condenser Lens for LD

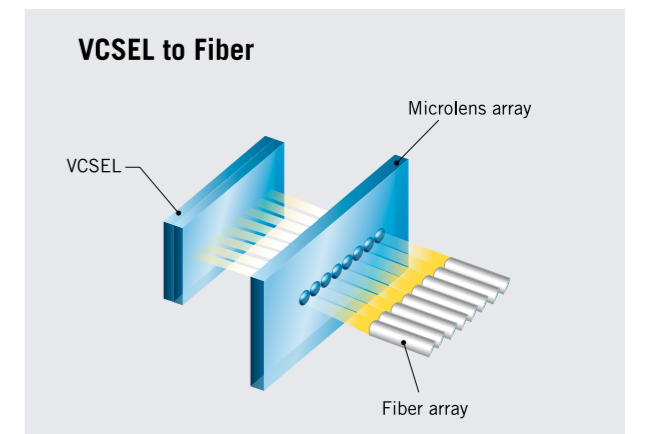
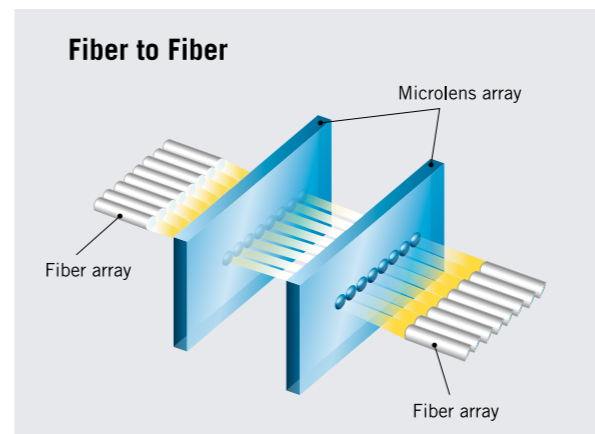
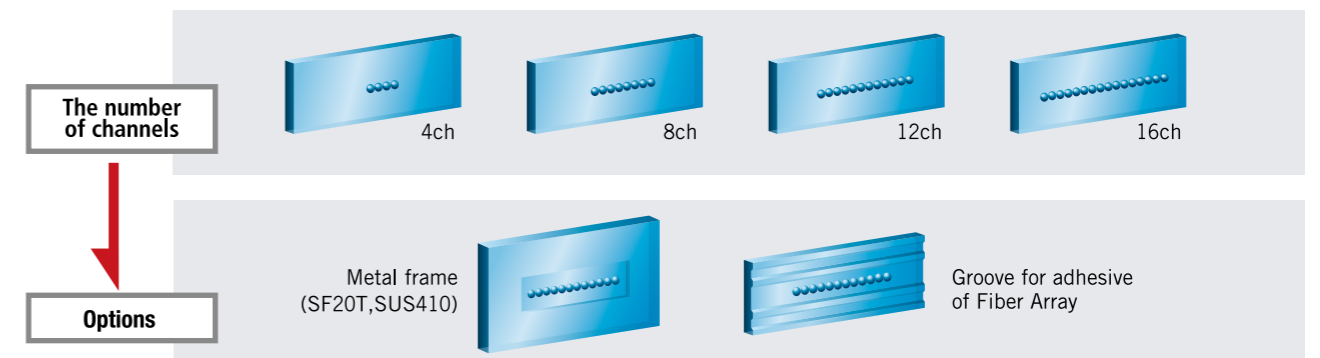
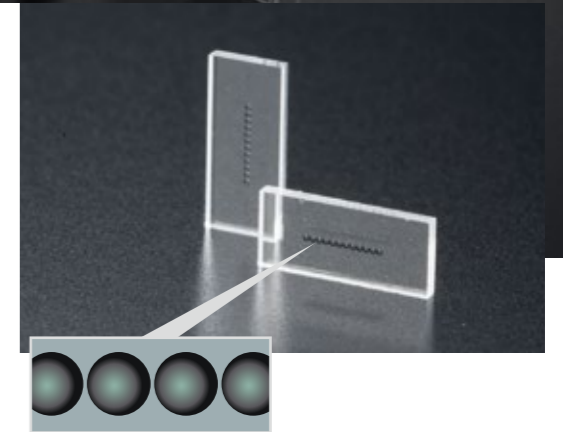

Specifications	
Dimension	Less than 7mm
Lens thickness	More than 0.3mm
Number of lenses	Upon request
Lens pitch error	Less than 1μm
Radius of curvature	More than 150μm
Maximum tilt	40°
PV error	Less than P-V=1μm
Surface roughness	Ra0.030μm

\*Lens custom-made to your specifications

Sample Specifications			
Applications	For Collimator		For LD coupling
Design wavelength	1550nm	1550nm	850nm
Focal length	0.6mm	0.35mm	0.22mm
Numerical aperture NA	0.18	0.14	0.3x0.2
Lens pitch	250μm	127μm	250μm
Number of lenses	12	40	12
Lens diameter	240μm	125μm	240μm
Lens thickness	0.6mm	0.76mm	0.55mm
Lens sag value	25μm	10μm	38μm

# Molded Special Form Optics

## Lens Array with Reflective Mirror

The lens array with a mirror, formed by glass molding

This high-precision microlens array has an integrated reflective mirror and ensures precise lens surface quality, pitch and tilt. Our microlens arrays with reflective mirror enable you to reduce the number of parts and the assembly time.

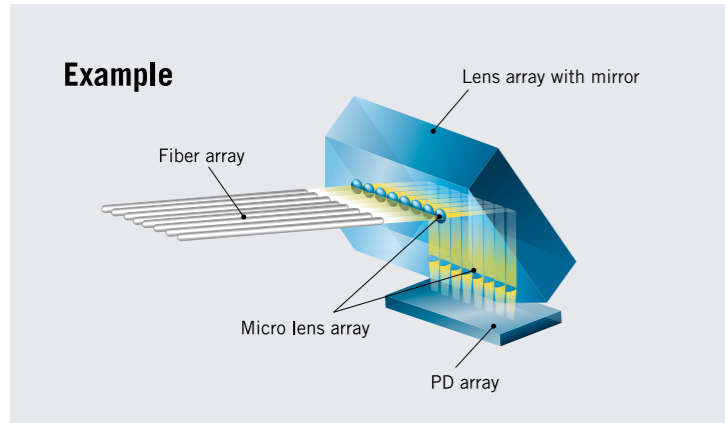
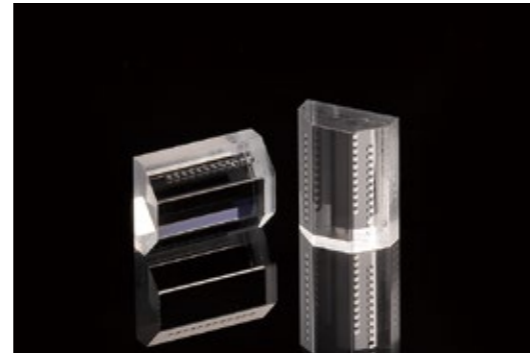

Sample Specifications	
Wavelength	1550nm
Number of lenses/ Pitch	12 / 0.25mm
WD at incident side	0.5mm
Effective NA at incident side	0.18
WD at exit side	0.5mm
Effective NA at exit side	0.18

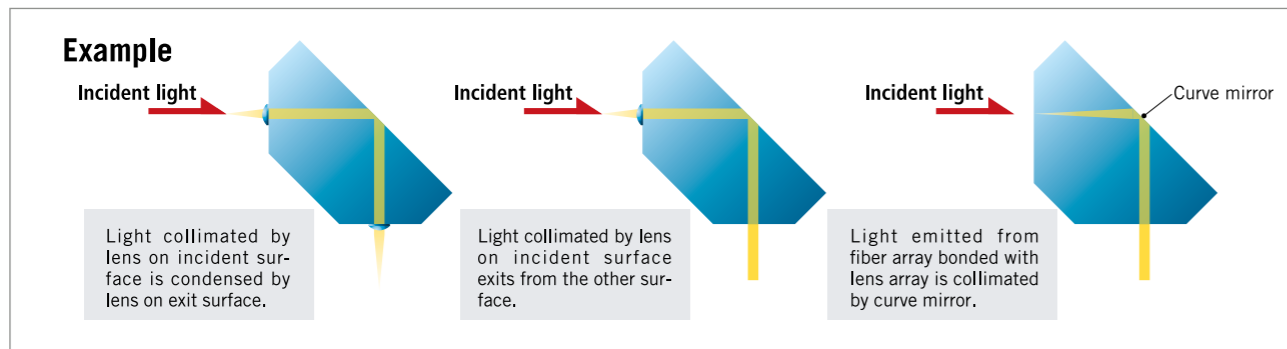

## Fly Eye Lenses

Ideal for homogenization of lasers and high-power LED light sources

Our fly eye lenses are formed with precision molding. Since they are made of glass, they possess excellent heat resistance and can be used in a wide range of wavelengths.

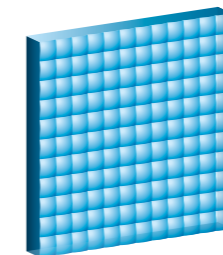
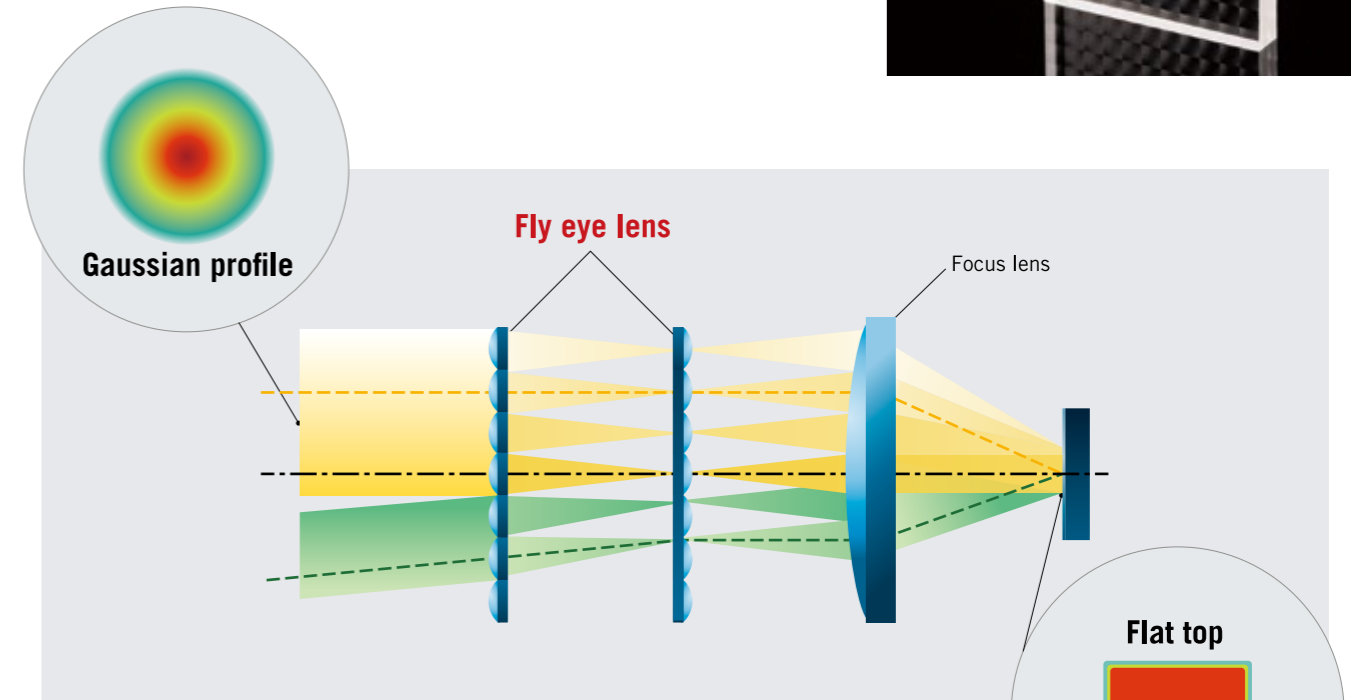
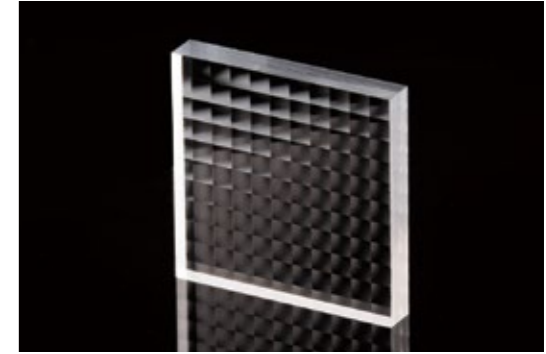

Sample Specifications	
Dimension	11mmx11mm
Lens thickness	1.8mm
Cell size	1x1mm
Focal length	29mm
Radius of curvature	

\*Lens custom-made to your specifications

## Aspherical Cylindrical Lens

Difficult to manufacture with conventional grinding methods, we have successfully produced aspheric cylindrical lenses with our precision molding technology. The use of molding tools minimizes variations between individual parts and makes mass production possible.

**Applications:** Laser line generator, Correction for elliptic beam from laser diode, Light condensing for line sensor

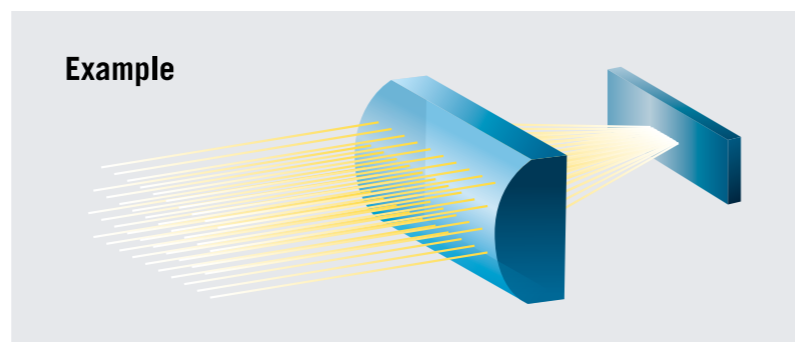

Sample Specifications	
Dimension	5mmx15mm
Center thickness	3mm
Focal length	6.0mm
Curvature radius (Aspherical)	3.09mm
PV error	P-V=<1μm





## Sumita Endoscope Lenses

1/18 lenses are ideal for small-diameter endoscopes in medical and industrial applications.

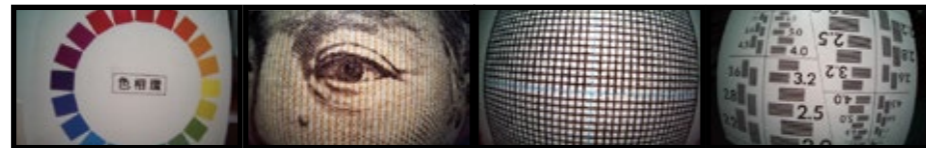

1/6 SEL140-038

1/11 SEL140-020L

1/11 SEL140-020

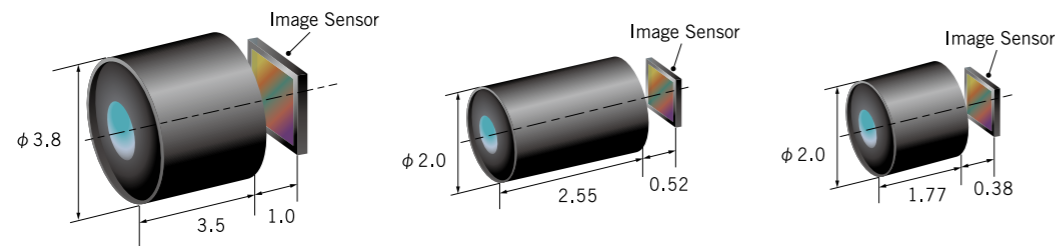

	1/6 Series		1/11 Series	
Model	1/6 SEL140-038	1/11 SEL140-020L	1/11 SEL140-020	
CMOS size	1/6 inch	1/11 inch		
Image circle	3.1 mm	1.49 mm		
Object distance	8 mm			
Depth of field	5 mm - 80 mm	3 mm - 100 mm		
Angle of view	140°	140°		
F-number*2	4.5	5.5		
Back focus*3	1.0 mm	0.52 mm	0.38 mm	
Distortion	<50%	<50%		
Relative illumination	>45%	>50%		
Chief ray angle	<35°	<33°		
Outer diameter	φ 3.8 mm	φ 2 mm (Changeable)		
Total length	3.5 mm	2.55 mm	1.77 mm	
IR cut filter	Included			
Lens Unit Cover Glass	Included			

\*1 Suitable for OmniVision's OH02A1S / OV2740(1/6),OH01A10(1/11) \*2 F-number is adjustable upon request. \*3 The measured distance between an image sensor plane and the rearmost glass element in the attached lens. \*4 The above are our standard specifications. Custom specifications are available upon request. \*4 Specifications may change without notice.

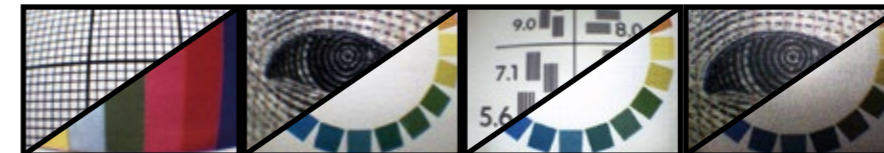

1/18 SEL080-015D

1/18 SEL100-015D

1/18 SEL120-015D

1/18 SEL100-015S

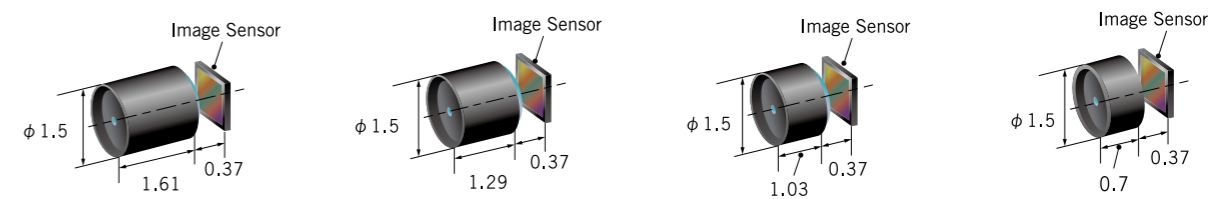

	1/18 Series			
Model	1/18 SEL080-015D	1/18 SEL100-015D	1/18 SEL120-015D	1/18 SEL100-015S
CMOS size	1/18 inch			
Image circle	1.0 mm			
Object distance	8 mm			
Depth of field	3 mm - 100 mm			
Angle of view	80°	100°	120°	100°
F-number*2	5.5			
Back focus*3	0.37 mm			
Distortion	<20%	<32%	<46%	<24%
Relative illumination	>80%	>70%	>60%	>50%
Chief ray angle	<25°			
Outer diameter	φ 1.5 mm			
Total length	1.61 mm	1.29 mm	1.03 mm	0.7 mm
IR cut filter	Not included			
Lens Unit Cover Glass	Included			

\*1 Suitable for OmniVision's OV6946 \*2 F-number is adjustable upon request. \*3 The measured distance between an image sensor plane and the rearmost glass element in the attached lens. \*4 The above are our standard specifications. Custom specifications are available upon request. \*5 Specifications may change without notice.

# Imaging

## HDIG Semi-flexible

Ultra-thin image bundles for minimally invasive treatments

With 10,000 pixels despite its small diameter, the HDIG allows for ultra-thin endoscopes with insertion tubes under 1.0 mm, while still delivering high-resolution imagery.

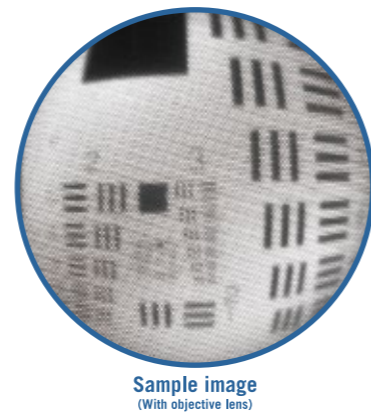
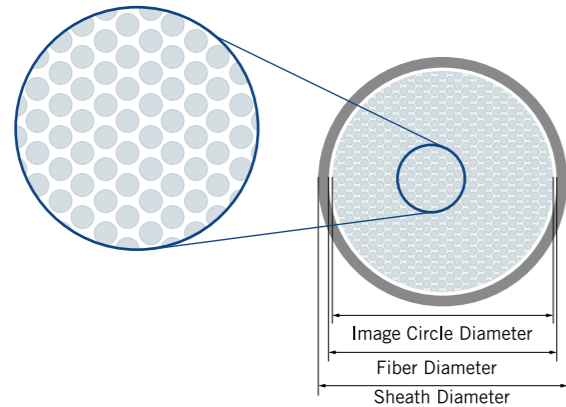
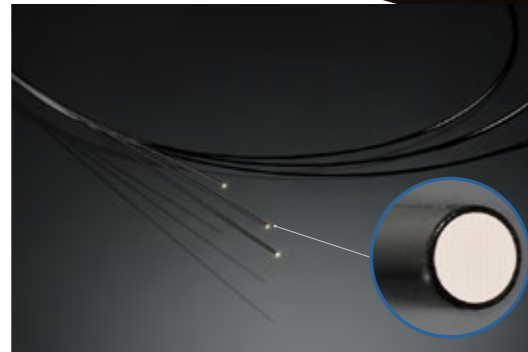

## Image Bundles Flexible

Leached image guides consisting of flexible and coherent fiber optic bundles are used for transmitting optical images from one end to the other, which are suitable for endoscopes in narrow and elongated spaces.

Fiber-optic components consisting of single fiber diameter 4–8 microns in bundles of thousands up to 16,000 – all precisely aligned together at both ends. Our image bundles power medical and industrial innovations in cutting-edge products.

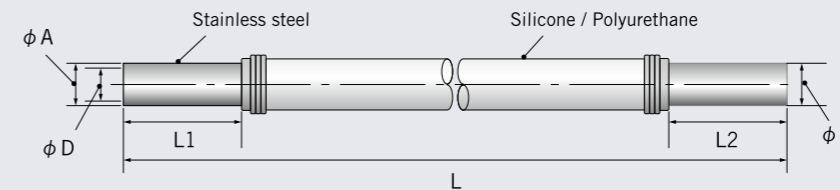
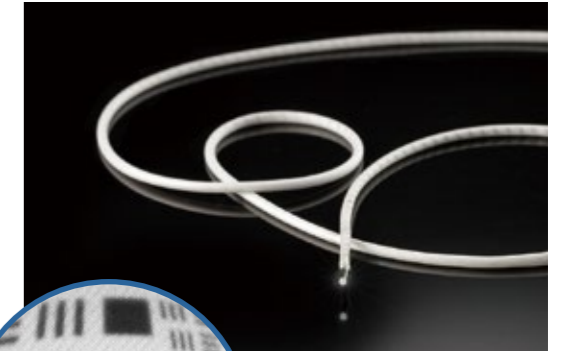

$\phi A$  = Outer diameter at objective side  
 $\phi B$  = Outer diameter at eyepiece side  
 $\phi D$  = Active area  
 L = Total length  
 L1, L2 = Ferrule length

An example of model

**056 F 1000 - 4.6**  
 Outer diameter at eyepiece    Total length    Single fiber diameter    Grade<sup>\*1</sup>



Standard Specifications										
Parameters	Units	Tolerances	Specifications							
Pixel Count	-	±10%	30,000	10,000	9,000	5,000	4,200			
Image Circle Diameter	µm	±15	550	327	235	185	210			
Fiber Diameter	µm	±15	570	350	250	195	230			
Sheathing Diameter	µm	±15	600	380	275	220	260			
Bending Radius	mm	-	-	R20						
Maximum Length	mm	-	500	2500						
Pixel Defect	%	-	< 0.1							
Non-Circularity	%	-	< 5							
Sheathing Material	-	-	Black Polyimide							
Objective Lens for pixel			30,000	10,000	9,000	5,000	4,200			
Field of View	degrees	±15	110	75	120	90	80	58	-	
W.D.	mm	-	8	5	7	10	5	-	-	
Depth of Field	mm	-	5 - 30				-	-		
Outer Diameter	mm	±0.02	0.7	0.43	0.37	-	-			

\*HDIG - No specification on angle of twist \*Objective lens – offered exclusively assembled with HDIG \*Please contact us for customized products

Specifications							
Model	Ferrule		Active area ( $\phi D$ )	Total length (L)	Single fiber diameter	Pixel count	Exterior material
	Objective side	Eyepiece side					
	mm		mm	µm	pix		
056F1000-4.6	$\phi 0.56 \times 3.6$	$\phi 0.64 \times 9.5$	$\phi 0.38$	1,000	4.6	8,100	Polyurethane
056F1000-6.9	$\phi 0.56 \times 3.6$	$\phi 0.64 \times 9.5$	$\phi 0.38$	1,000	6.9	3,600	
064F1000-6.4	$\phi 0.64 \times 3.8$	$\phi 0.7 \times 13.0$	$\phi 0.4$	1,000	6.4	5,200	
064F1050-6.4	$\phi 0.64 \times 3.8$	$\phi 0.7 \times 13.0$	$\phi 0.4$	1,050	6.4	5,200	
082F1000-7.0	$\phi 0.82 \times 3.5$	$\phi 0.82 \times 3.5$	$\phi 0.5$	1,000	7.0	7,000	Silicone
122F0760-7.4	$\phi 1.22 \times 4.0$	$\phi 1.22 \times 11.5$	$\phi 0.89$	760	7.4	16,000	
126F0760-7.4	$\phi 1.26 \times 3.5$	$\phi 2.04 \times 13.2$	$\phi 0.89$	760	7.4	16,000	
14F0545-8.1	$\phi 1.4 \times 3.5$	$\phi 1.4 \times 11.5$	$\phi 1.0$	545	8.1	16,000	

\* We distinguish between grades such as ESA and SA based on the number of allowable defects. Kindly contact us for the details.

\* Customized leached fiber bundles are available upon request.

### Raw Optical Fiber

Sumita offers a wide selection of the highest-quality raw optical fibers with a variety of opening angles. Our fibers cover the UV, VIS and NIR spectra – tailored to your specific requirements, operating wavelengths and environmental conditions.

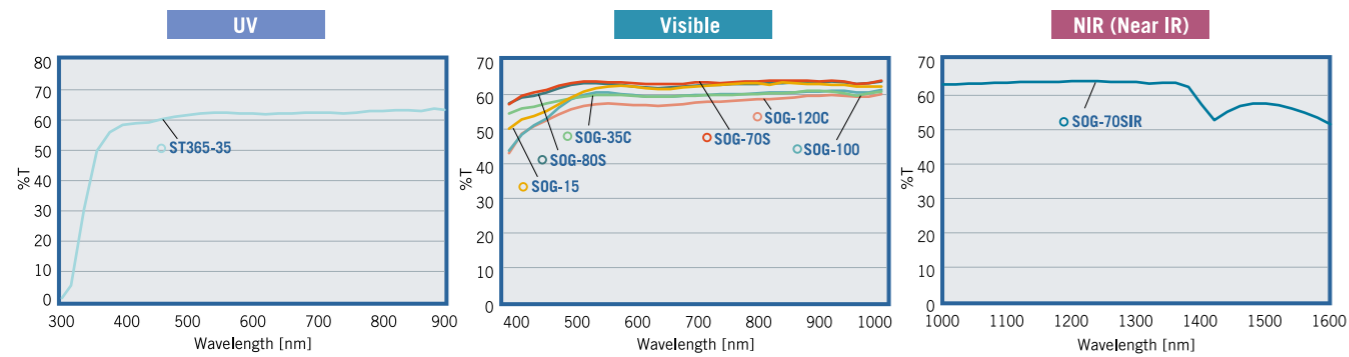

Thickness and length of measured fiber bundles (mm)

**ST365**  $\phi$  4 x L1000 (Single fiber diameter : 50 $\mu$ m)    **SOG**  $\phi$  5 x L1000 (Single fiber diameter : 50 $\mu$ m)

Optical Fiber Lineup				
Wavelength	Material	Type of optical fiber	NA	Opening angle (2 $\theta$ )
Visible	Multi-component glass	SOG-120C	0.86	119°
		SOG-100	0.77	100°
		SOG-80S	0.63	79°
		SOG-70S	0.57	70°
		SOG-35C	0.31	35°
		SOG-15	0.14	16°
NIR		SOG-70SIR	0.57	70°
UV		ST365-35	0.32	38°

Note: ST365-35 fibers may exhibit solarization depending on the wavelength and intensity of the light source, the operating temperature, etc.

### Bare Optical Fiber

Sumita develops glass materials and draws optical fibers in-house. This allows us to control every stage of optical fiber production and to respond to specific customer requirements. Contact us with your custom specifications beyond the standards shown below.

The following three packaging options are available depending on fiber type, bundle size and length."

#### Bobbin

- The most economical way to purchase bare fiber optics

Available fiber type	SOG-70S		
Individual fiber diameter	30 $\mu$ m	50 $\mu$ m	
Fiber count	100	200	200
Length	3000 m	3000 m	2000 m



#### Reel

- A string is wrapped around the optical fibers to prevent the fiber bundle from tangling
- Bundle diameter is inversely proportional to its bundle length. A larger bundle diameter decreases the bundle length and vice versa

Available fiber type	SOG-120C / SOG-80S / SOG-70S	
Individual fiber diameter	30 $\mu$ m	50 $\mu$ m
Fiber count	$\phi$ 0.2 - 2.45 mm	$\phi$ 0.3 - 3.4 mm
Length	50 - 3000 m	



#### PP (Polypropylene) Sleeve

- Polypropylene sheathing wraps an optical fiber bundle to keep it secure during shipping and storage
- A heat shrink tube seals one end of a fiber bundle to prevent it from loosening

Available fiber type	SOG-120C / SOG-80S / SOG-70S	
Individual fiber diameter	30 $\mu$ m	50 $\mu$ m
Fiber count	$\phi$ 0.45 - 5.0 mm	$\phi$ 0.75 - 4.7 mm
Length	12 m	



## Various Assembly Options

### Heat-fused Light Guides

#### Improvement in light intensity and heat resistance by fusing the end tip

Hot-fused light guides feature individual fibers fused together at high temperatures, eliminating the need for epoxy.

Epoxy used in light guides causes an unintentional absorption of light that prevents light from being transmitted and creates heat at the end of the light guides.

As hot-fused light guides are not bonded with epoxy, they have improved heat resistance.

Also, light intensity is improved as additional optical fibers occupy the space previously taken by epoxy, maximizing the effective illumination area.

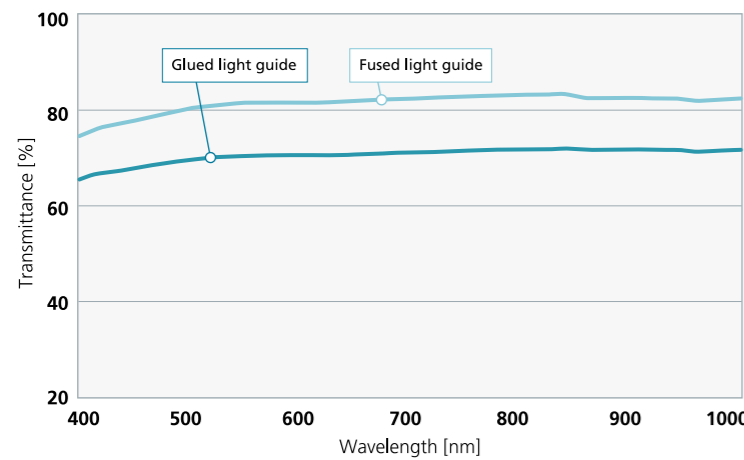
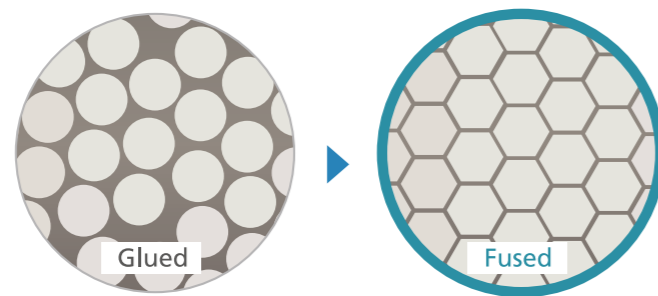

#### Sample evaluation conditions

Type of Optical Fiber: SOG-70S / 50[ $\mu$ m]  
 Bundled Diameter:  $\phi$  10[mm]  
 Length: 1,000[mm]

### Blended fiber

Blending optical fibers with different numerical apertures will provide well balanced lighting regardless of distance.



## Various Application Examples

### Randomization for uniform light distribution

The fibers randomized by highly skilled workers output uniform light distribution and evenly distribute light over all branches.

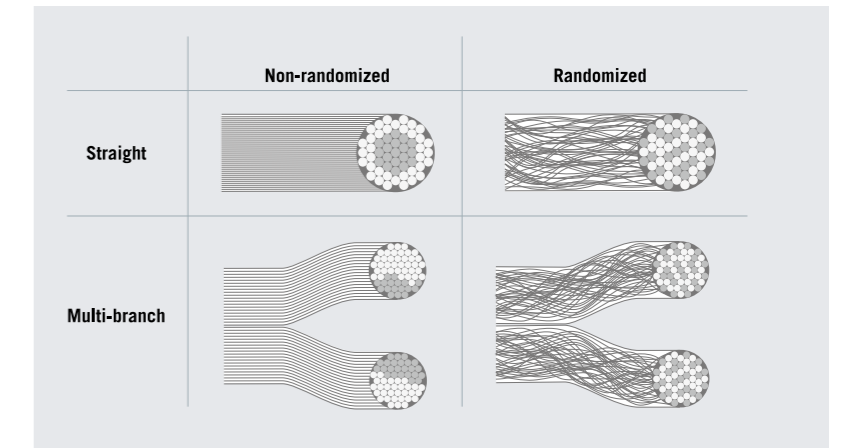

### Analysis equipment, in-vitro diagnostic device, and more

- Incident light at the specified wavelength is reflected back through the optical fibers to the surface of the measured object (light excitation).
- Excited reflected light is collected with the optical fibers, connecting it to analytical equipment for analysis and diagnostics.

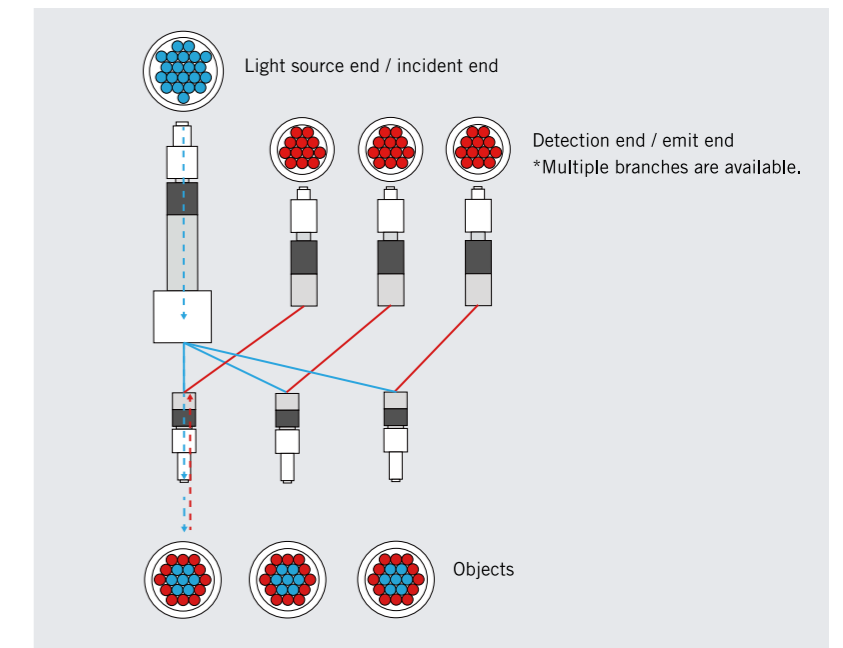

### The following light beams are available

- **Incident end  $\rightarrow$  Emitting end**  
Shape transformation, e.g. circular incidence and rectangular emission
- **Multi-branches  $\rightarrow$  Combining**  
Multi-point lighting, multi-point detection, combination of different colors of
- **One-to-one uniformity**  
Uneven light at a light source end is transformed into uniform output through the optical fiber.

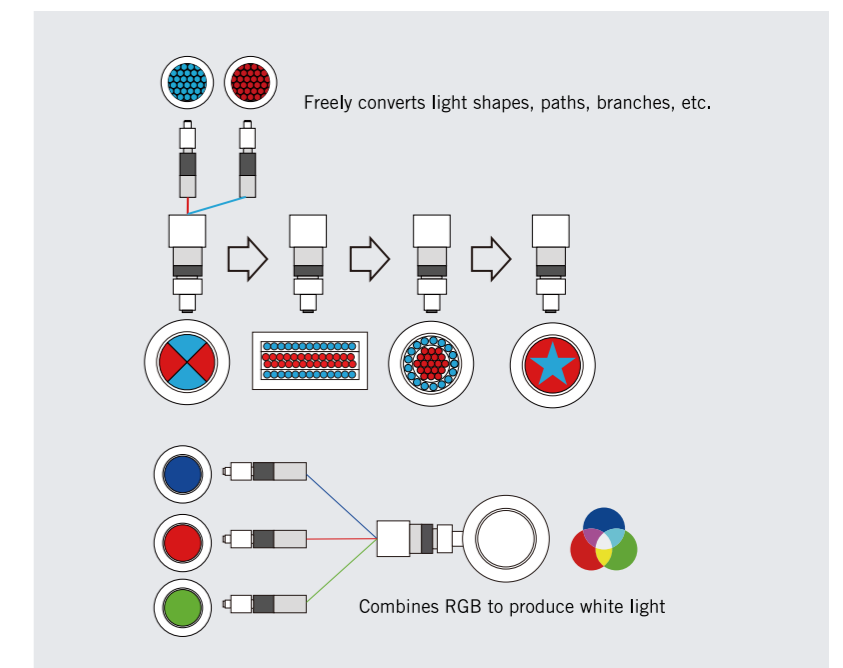

# Light Guide



## Light Guides for Endoscopes

A small-diameter cable as the first choice for medical and industrial endoscopes.

As specialists in the field of lens and fiber technology, we engineer a wide variety of custom light guide assemblies beyond standard-branch types.

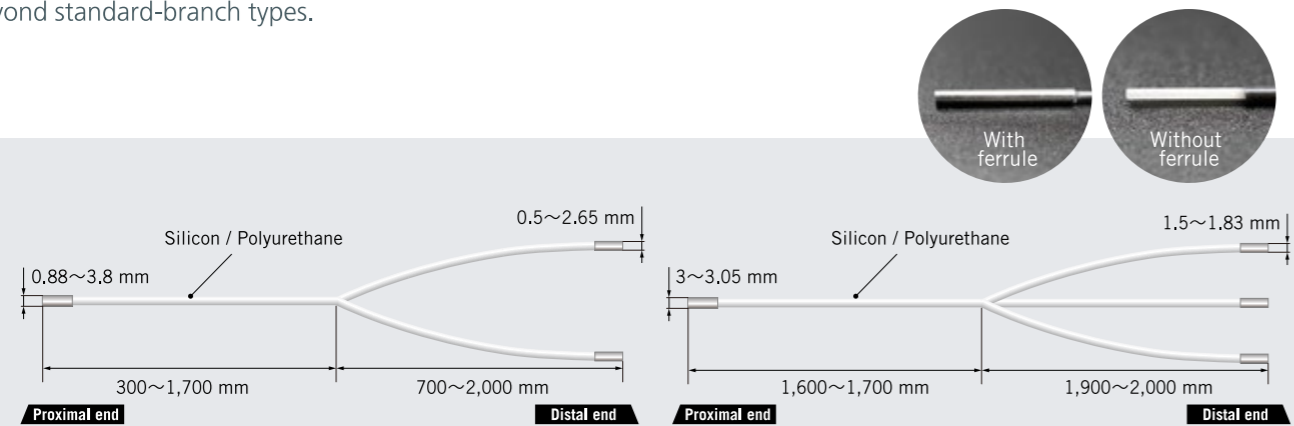

\* These drawings are for our standard model. Custom dimensions are possible. Contact us with your specific requirements.

## Light Guide for Medical Devices

We offer a wide variety of light guides for medical devices, such as ultra thin light guides and/or multiple branch light guides. Our light guides are high precision, made in Japan and can also be customized to your individual needs.

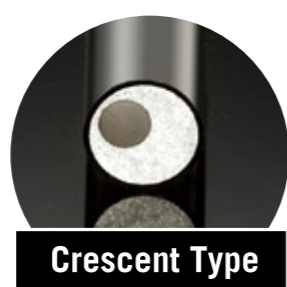

## Light Rod Conduits/ Fiber Rods

**Rigid Fiber Rods have excellent light transmission**

Light Rod Conduits are rigid fiber rods which consist of core and cladding. Cores and claddings are fused together without adhesive. Light Rod Conduits have higher transmittance than epoxied light guides and are more resistant to high temperatures.

**Single Rod**

Single rods consist of a core and a cladding.

**Conduit**

Conduits consist of a lot of cores and claddings fused together. (The number of fibers are 1900 - 1950)

**Pressed Conduit**

The conduit processed by reheat press.

**Tapered Conduit**

The angle of view can be changed by the shape of the taper.

Specifications					
Type of rod	Name	NA	Opening angle	Diameter	Length
Conduit	SMC-120	0.86	119	φ 1.5~13mm	2~300mm (Depends on outer diameter)
	SMC-80	0.64	80		
	SMC-70	0.57	70		
	SMC-35	0.30	36		
	SMC-15	0.15	18		
Pressed conduit	SPC-70	0.56	68	Please contact us	
Single rod	SSR-160	0.98	163	φ 0.5~10mm	2~1,000mm (Depends on outer diameter)
	SSR-120	0.86	119		
	SSR-80	0.64	80		
	SSR-70	0.57	70		
Glass rod	Each glass type	-	-	φ 0.5~10mm	2~900mm

## Long experience and cutting-edge technologies for minimally invasive treatments.

SUMITA has created a wide variety of optical components since its foundation in 1953, from melting optical glass materials to optical fibers and molded aspheric lenses made with high precision dies. Our advanced solutions are essential across many fields, such as the telecommunication, semiconductor, image processing and medical industries. We are a trusted partner to our customers, meeting individual needs with unique products.

We will continue to meet our customers' needs – from individual components to semi-assembled units – by utilizing our proven technologies and products. We continue to pioneer advanced medical devices that drive the development of new endoscopes for minimally invasive treatments.

### LIGHT GUIDE

We manufacture light guides to customer specifications, 100% custom-made.

**P.18  
Optical Fiber**



**P.22  
Light Guides for Endoscopes**



**P.23  
Conduits**



### IMAGING

Providing high resolution and thin image bundles.

**P.16  
HDIG**

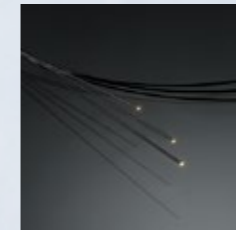

**P.17  
Image Bundles**

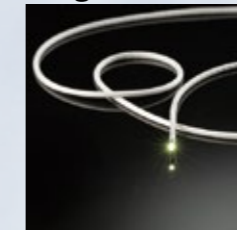

### LENS

We can support optical design.





**P.14  
Sumita Endoscope Lenses**

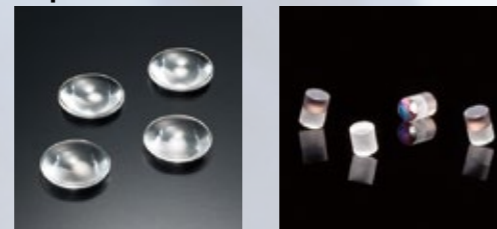

**P.10  
Aspherical Lenses**



### Endoscope Sub-Assemblies

-  Lens + CMOS
-  Lens + CMOS + Light guide
-  Lens + Image bundle
-  Lens + Image bundle + Light guide

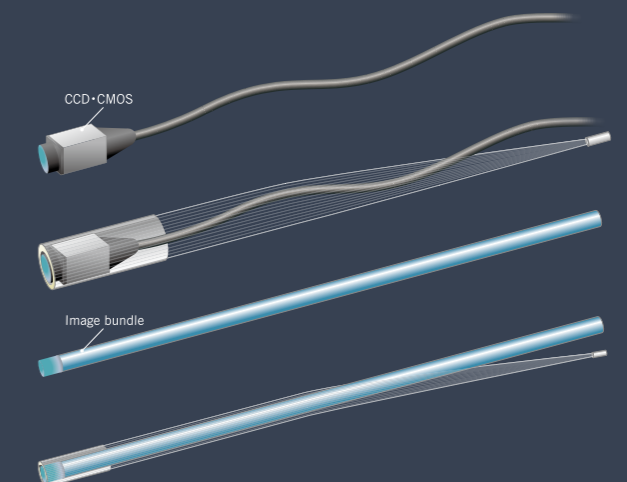

## Headquarters & Urawa Factory



Established | October 13, 1953  
Location | Saitama, Japan

4-7-25 Harigaya, Urawa-ku,  
Saitama-City, Saitama 330-8565 Japan  
TEL:+81-48-832-3165  
w-contact@sumita-opt.co.jp

## Sumita Photonics



Established | 1984  
Location | Fukushima, Japan  
Business | Assembling optical fiber

## Our Factory is Licensed for the Medical Industry

- 2010 Medical Device Manufacturer
- 2013 ISO13485 certification  
Medical Device Repair  
Veterinary Medical Device Manufacturer
- 2014 Second-class Medical Device Marketing Authorization Holders

## ISO certificates

ISO9001:2015 (Quality management system),  
ISO 13485:2016 (Quality management system of medical equipment)  
and ISO14001:2015 (Environmental management system) are certified.

## Tajima Tabehara/ Nagano Factory



Established | 1970  
Location | Fukushima, Japan



174-1 Tabehara, Tajima, Minamiaizu-machi,  
Minamiaizu-Gun, Fukushima 967-0004 Japan

Factory for Medical Device MFG

## Sumita Optical Glass Europe GmbH



Established | 2005  
Location | Nuremberg, Germany  
Business | Sales & Marketing in Europe

Andernacher Str. 23, 90411 Nuremberg,  
Germany  
TEL:+49 911 376683-60  
info@sumita.eu

## SUMITA OPTICS (Dongguan) Co., Ltd. (China)



Established | 2018  
Location | Dongguan, China  
Business | Sales & Marketing in China

Building 1 # , Science road 195#, Dongkeng  
town, Dongguan, Guangdong, China

Create the future  
[www.sumita-opt.co.jp](http://www.sumita-opt.co.jp)

**SUMITA** new glass & fiber optics **Headquarters SUMITA OPTICAL GLASS, Inc.**  
4-7-25 Harigaya, Urawa-ku, Saitama City, Saitama 330-8565 Japan  
TEL. : +81-48-832-3165 FAX : +81-48-824-0734  
E-mail : [w-contact@sumita-opt.co.jp](mailto:w-contact@sumita-opt.co.jp)  
URL : [www.sumita-opt.co.jp](http://www.sumita-opt.co.jp)

**European office Sumita Optical Glass Europe GmbH**  
Andernacher Str. 23, 90411 Nuremberg, Germany  
TEL. : +49 911 376683-60  
E-mail : [info@sumita.eu](mailto:info@sumita.eu)



2026.04